

JOB NAME _____ CONTRACTOR _____
 LOCATION _____ APPROVAL _____
 ENGINEER _____ CONT. P.O NO. _____
 APPROVAL _____ REPRESENTATIVE _____

ANSI 150LB Black Steel Roll Groove

Size	A	B	C	D	E	F	G	H	Drilling Template		
									No.	Diameter	PCD
2"	0.625	0.344	2.36	2.38	0.15	4.0	5.98	0.63	4	0.75	4.76
2.5"	0.625	0.344	2.71	2.88	0.20	4.0	7.01	0.63	4	0.75	5.51
3"	0.625	0.344	3.35	3.5	0.21	4.0	7.52	0.63	4	0.75	5.98
4"	0.625	0.344	4.32	4.51	0.23	6.0	9.02	0.75	8	0.75	7.48
5"	0.625	0.344	5.38	5.58	0.26	6.0	10.00	0.75	8	0.87	8.5
6"	0.625	0.344	6.44	6.64	0.28	6.0	10.98	0.87	8	0.87	9.49
8"	0.75	0.468	8.42	8.52	0.32	6.0	13.5	0.87	8	0.87	11.73
10"	0.75	0.468	10.6	10.77	0.36	8.0	15.98	1.02	12	0.98	14.25
12"	0.75	0.468	12.5	12.77	0.38	8.0	19.02	1.06	12	0.98	17.01

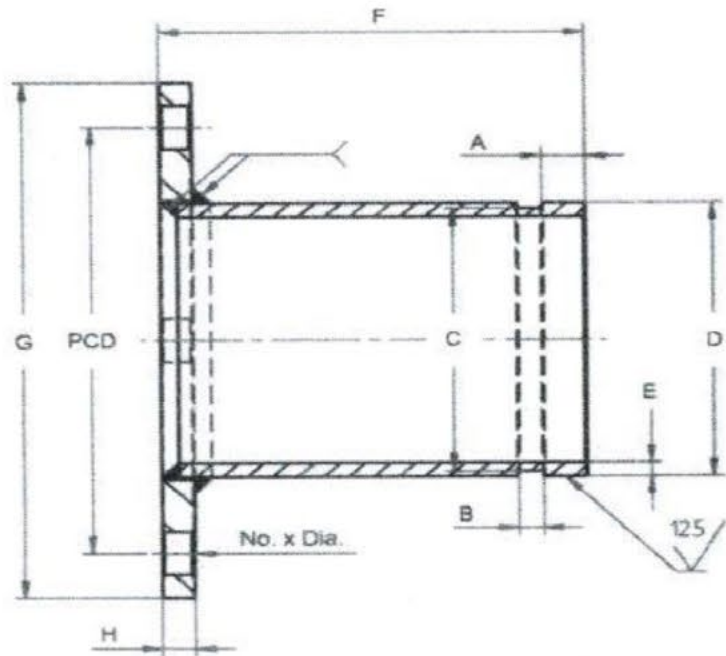
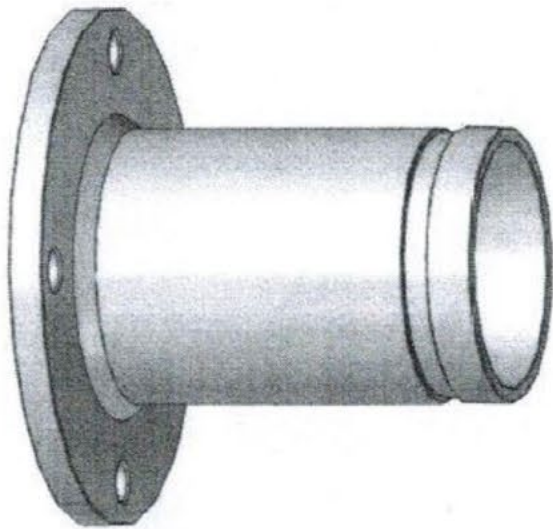

Spec sheet measurements accurate at time of printing